



MODEL MF200 'PRESSURE PAL' MINI SYSTEM FEEDER

The 'PRESSURE PAL' is ideal for feeding and pressurizing closed hydronic systems that do not require cold static fill pressures higher than 170 kPa (25 psig). It is compatible with both water and glycol/water solutions. Perfect for small boiler/chiller systems, snow/ice melt circuits, outside air heating/cooling glycol coils, solar heating systems.



FEATURES and BENEFITS

- 25 liter (6.6 US gallon) tank for storage and mixing
- UL listed Power supply plugs into any standard 115 VAC outlet
- Diaphragm pump can run dry without damage
- No direct connection to potable water supply eliminates need for backflow prevention
- Make-up fluid stored in the feeder tank can be pre-treated
- Diverter valve allows easy purging of air on initial start-up, and manual agitation of solution
- Prevents major floods - in the event of system rupture, only the contents of the tank will be pumped into the system
- Provides leak detection - dropping fluid level provides immediate notice that the system has developed a leak
- Fluid drained for service can easily be put back into the system
- Fluid level switch shuts the pump off if the storage tank level gets too low

Represented By:



INDUSTRIES LIMITED

MF200 HYDRONIC SYSTEM FEEDER TECHNICAL INFORMATION

WEIGHT - 3.2 kg, 7 lbs.

ELECTRICAL

Power supply adapter (UL listed)
100-240VAC/50-60Hz/1 to 24 VDC
LED Power Light

PUMP PERFORMANCE

0.04 l/s (0.7 gpm) @ free flow
Self-priming up to 1.2 m (4 feet)

SPECIFICATION

Hydronic system feeder shall be AXIOM INDUSTRIES LTD. Model MF200. System shall include 25 litre (6.6 U.S. gallon) storage/mixing tank with molded-in level gauge, 125 mm (5") fill/access opening and cover; graduated funnel with stainless steel filter; pump suction hose with inlet strainer and check valve; pressure pump with fuse protection; low fluid level pump cut-out float switch; manual diverter valve for purging air and agitating contents of storage tank; snubber with pressure switch, adjustable from 70 kPa (10 psig) to 170 kPa (25 psig) cut-out pressure; factory cut-out pressure set to 115 kPa (17psig); and liquid filled pressure gauge. Unit to c/w UL listed power supply adapter with LED power indicator light, 100-240VAC/50-60Hz/1 to 24 VDC, supplied loose for field installation.

Feeder shall be compatible with glycol solutions of up to 50% concentration. Pump shall be capable of running dry without damage. Unit shall be completely assembled.

ACCESSORIES

- MF200-1430 – Tank Mounting Shelf
- RIA10-1-SAA – Low level Alarm Panel c/w Remote Monitoring Dry Contacts and Selectable Audible Alarm

LIMITED WARRANTY

The MF200 is warranted against defects in materials and workmanship for one year.

Project _____ Location _____
 Consultant _____ Contractor _____
 Unit Tag _____ Sales Agent _____

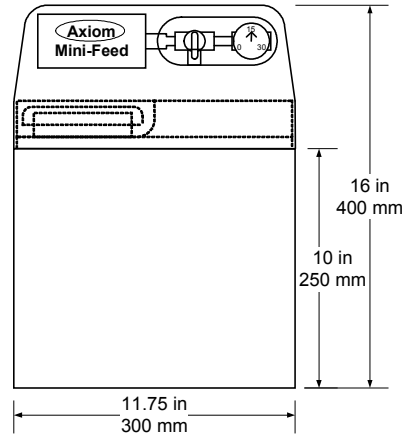

Depth - 11.75 in 300 mm
 Clearances – Right Side and Top - 12 in 305 mm
 Weight When Full 60 lbs/27 kg.
 Discharge 1/2" FPT



INDUSTRIES LIMITED

Specification:

AXIOM Industries Hydronic Mini System Feeder: MF200

Hydronic system feeder shall be AXIOM INDUSTRIES LTD. Model MF200. System shall include 25 litre (6.6 U.S. gallon) storage/mixing tank with molded-in level gauge, 125 mm (5”) fill/access opening and cover; pump suction hose with inlet strainer and check valve; pressure pump with fuse protection; low fluid level pump cut-out float switch; manual diverter valve for purging air and agitating contents of storage tank; pressure switch with snubber, each individually adjustable from 70 kPa (10 psig) to 170 kPa (25 psig) cut-out pressure; factory cut-out pressure set to 115 kPa (17psig); and liquid filled pressure gauge. Unit to be c/w UL listed and fused power supply adapter with LED power indicator light, 115/60/1 to 24 VDC 50 watts AC, supplied loose for field installation.

Feeder shall be compatible with glycol solutions of up to 50% concentration. Pump shall be capable of running dry without damage. Unit shall be completely assembled.

OPTION

MF200-1430 – Tank Mounting Shelf

RIA10-1-SAA – Low level Alarm Panel c/w Remote Monitoring Dry Contacts and Selectable Audible Alarm

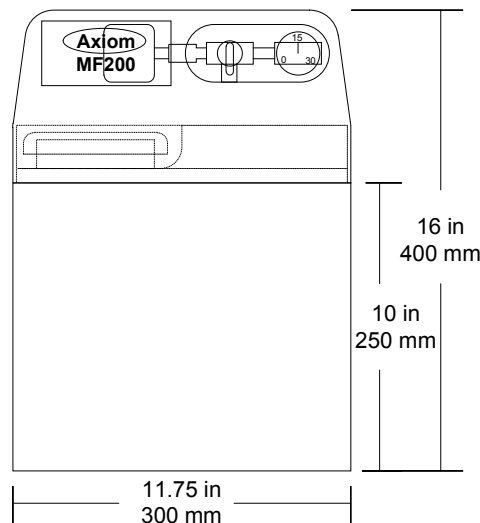

Depth - 11.75 in 300 mm
Clearances – Right Side - 12 in 305 mm
Weight When Full 60 lbs/27 kg.
Discharge 1/2" FPT